

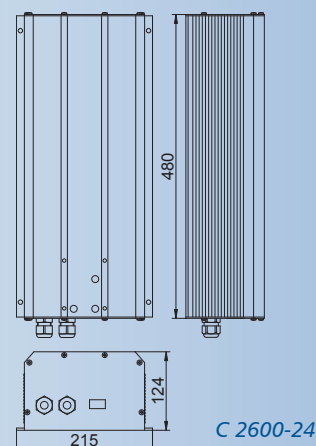

Sine Wave Inverter



Power class **1600 - 4000 W**



Steca Compact

1600-12, 2600-24, 4000-48

The Steca Compact series is specially designed for hybrid systems. The devices consist of a sine wave inverter with a high overload capacity, a battery charger and a transfer system. The in-built multifunctional contact enables you, for example, to start a diesel generator to recharge batteries or to cut the power for less priority loads when the battery is lower than a given threshold. Even if you only use the device's sine wave inverter, Steca Compact is still very cost effective. The integrated power sharing function ensures that the transfer system always provides the connected loads with the desired power.



Inverter-Charger Compact	1600-12	2600-24	4000-48
Nominal input voltage (V)	12	24	48
Input voltage range (V)	9.5 - 16	19 - 32	38 - 64
Output voltage	230 V~ +0 / -10 % (pure sine wave)		
Output frequency	50 Hz +/-0.05 %		
Continuous power (VA)	1300	2300	3500
Max. power 30 min. (VA)	1600	2600	4000
Max. power 5 sec. (VA)	3900	6900	10500
Maximum efficiency (%)	94	95	95
Consumption Stand-by (W)	0.6	0.9	1.4
Load detection (Stand-by)	adjustable: 1 - 25 W		
Charging current, adjustable (A)	0 - 55	0 - 55	0 - 50
Input current balance adj., power sharing	1 - 16 A		
Minimum input voltage	adjustable from 150 to 230 VAC		
Battery monitoring	LVD, HVD, floating and equalisation voltage adjustable by user		
Max. current / power on transfer system	16 A / 3.7 kVA		
Switching time	< 20 ms		
Cable length battery	165 cm		
Operating temperature	-20 °C to +55 °C		
Protection class	IP 20 / with optional top cover: IP 23		
Weight (kg)	16.0	17.1	29.4
Dimensions (l) x 215 x 124 (mm)	480	480	670

Technical data at 25 °C / 77 °F

Options

- Types with 230 V / 60 Hz
- Remote control RCC-01
- Protection cover C-IP 23 to enhance the protection class
- Terminal protection cover CFC-01 to avoid hazardous contacts with strain relief clamps
- Temperature sensor CT35 to correct the operation voltages according to the actual battery temperature
- Remote control RPS-01 for the function power sharing

Features

- Power range 1,600 - 4,000 W
- Adjustable battery charger included
- Excellent overload capabilities
- Adjustable, automatic load detection
- Usable as back-up or UPS
- Adjustable power sharing
- Best reliability
- Multifunction switch

Electronic Protections

- Battery deep discharge protection
- Battery over voltage shut down
- Over temperature and over load protection
- Short circuit protection
- Reverse polarity protection by internal fuse
- Acoustic warning before battery low or overheating disconnection

Displays

- Operational status inverter and state of charge by 17 LEDs
- Power monitor for topical power and charging current